



NIMMI 

KITCHEN
FITTINGS



NIMMI APP



Features

- Comprises of two melamine coated wooden shelves with anti-slip coating
- Chrome plated rails made from high grade steel
- Can be used to store utensils, small appliances and cutlery
- German made bearing tested to last at least 50,000 cycles

Technical Specification

- For corner cabinets with size 900 X 900mm
- Minimum inner cabinet depth 524mm
- Weight capacity 15Kg per shelf
- Variable installation height from 600 - 730 mm
- Non-handed installation



Min. Inner Cabinet width OW-36	Min. Space Required for the access	Inner Cabinet height range	Min. Inner Cabinet Depth	Item Code
864	320	600 - 730	524	NKF 902

Cabinet Preparation

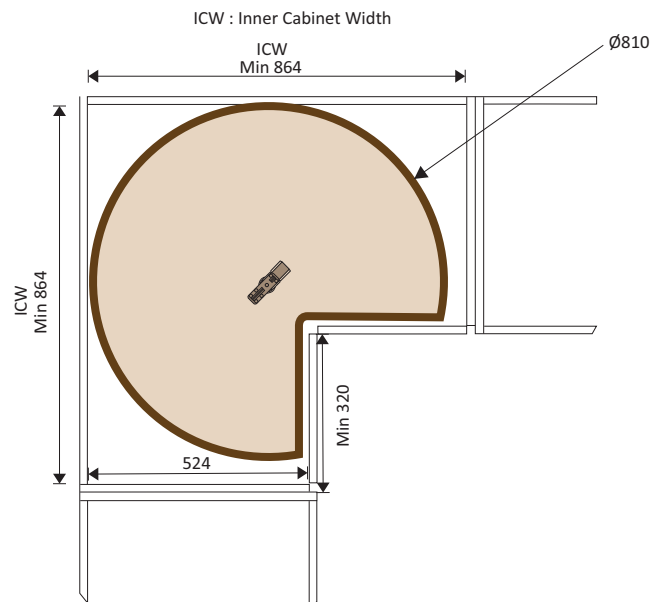

Features

- Integrated soft closing damping system
- Unique mechanism allows for 100% access to both the baskets
- Modern design with transparent panels for maximum visibility
- Glass Panels are made from toughened glass

Technical Specification

- For corner cabinets with size 500 X 800mm
- Minimum Inner cabinet depth 500mm
- Weight capacity 5Kg per basket
- Minimum Cabinet Height is 650mm
- Universal; Can be installed to open on left or right side
- Order frame and tray separately



Min. Inner Cabinet Width	Clear Space Required for the tray to open	Min. Inner Cabinet Height	Min. Inner Cabinet Depth
764	430	614	500

Cabinet Preparation

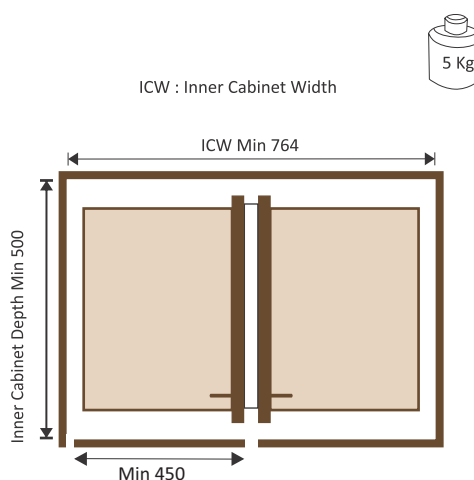
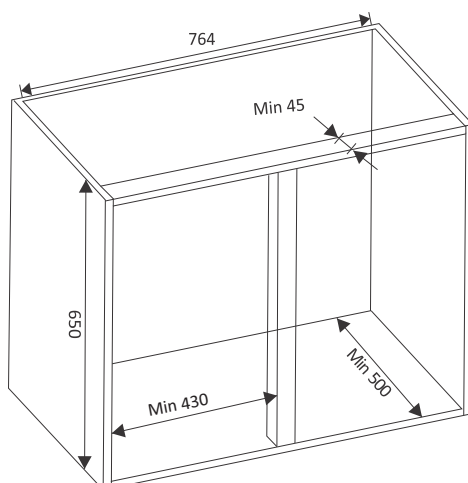

Features

- For maximum and unrestricted access to corner cabinets
- Shelves can be pulled out individually and completely
- Comes with soft-closing damping system
- Shelves are made of chrome-plated flat wires with melamine coated board for a sleek and modern look
- Pre cut anti skid mat can be ordered separately-NKF911 MAT



Technical Specification

- Minimum Inner cabinet depth required is 500mm
- Left and Right handed units to be ordered separately
- Weight capacity 10Kg per shelf
- Maximum suitable cabinet inner height is 740mm
- Order fitting and anti-skid matt separately

Min. Inner Cabinet Width	Clear Space Required for the tray to open	Inner cabinet height range	Min. Inner Cabinet Depth	Tray opening Direction	Item Code
864	430	650 - 740	500	Left	NKF-911L
864	430	650 - 740	500	Right	NKF-911R

Cabinet Preparation

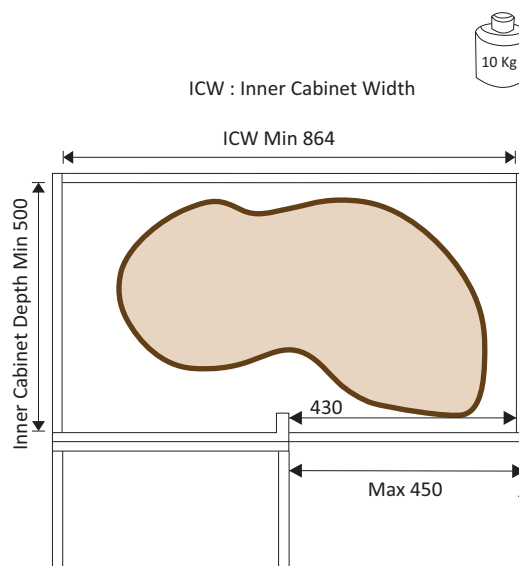
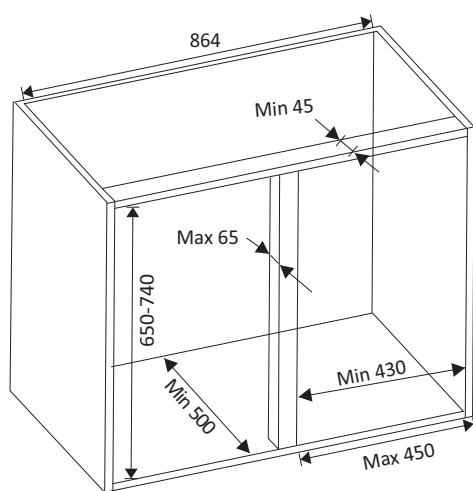

Features

- Universal access
- Trivalent chrome plated steel rails for sleek and modern look
- Can be used to store bottles, cans and glasses
- Tested for 50,000 cycles
- Available finishes in CP & Grey

Technical Specification

- For cabinet width 150mm
- Minimum Inner cabinet depth 500mm
- Total weight capacity 25Kg
- Right side installation

Min. Inner Cabinet Width	Min. Inner Cabinet Depth	Basket Size W x D	Item Code
114	500	95 x 470	NKF 921



Cabinet Preparation

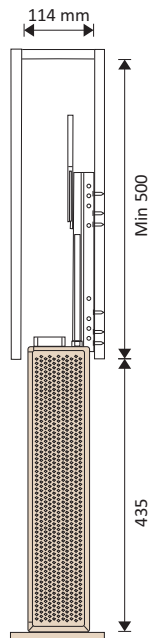

Features

- Universal access
- Premium anti slip mat included with tray
- Trivalent chrome plated steel rails for sleek and modern look
- Can be used to store bottles, cans, snacks and glasses
- Tested for 50,000 cycles
- Available finishes in CP & Grey

Technical Specification

- Minimum inner cabinet depth 500mm
- Total weight capacity 25Kg
- Handed installation

Min. Inner Cabinet Width	Shelf size	Min. Inner Cabinet Depth	Cabinet Size	Basket Size W x D	Item Code
164	100	500	200	110 x 470	NKF925
264	200	500	300	210 x 470	NKF926



Cabinet Preparation

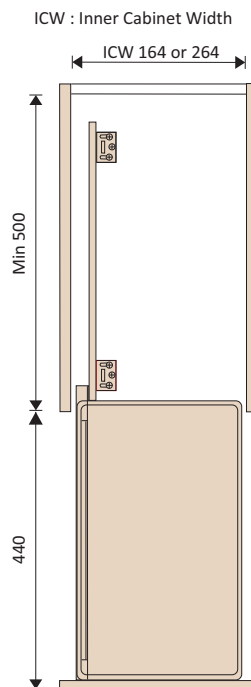

Features

- Suitable for use under the sink cabinet
- Modern design with transparent panels for maximum visibility
- Hooks allow hanging of cleaning accessories

Technical Specification

- For cabinet width 250mm
- Minimum inner cabinet depth 500mm
- Total weight capacity 25Kg
- Non-handed installation



Min. Inner Cabinet Width	Min. Inner Cabinet Depth	Basket Size W x D	Item Code
214	500	140 x 464	NKF930

Cabinet Preparation

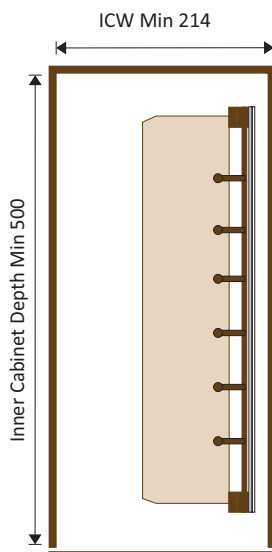

Features

- Two / Three layer glass pullout
- Pullout in modern design with transparent panels for maximum visibility
- Available in assortment of cabinet sizes (150/200/300mm)
- Aluminium baskets ensures superior finish and durability

Technical Specification

- Minimum inner cabinet depth 500mm
- Weight capacity 10Kg per basket
- Universal installation for left and right side access



Min. Inner Cabinet Width	Min. Inner Cabinet Depth	Cabinet Size	Basket Size W x D	Item Code
114	500	150	92 x 493	NKF931 - 2 Layer
164	500	200	142 x 493	NKF932 - 2 Layer
264	500	300	242 x 493	NKF933 - 2 Layer
264	500	300	242 x 493	NKF934 - 3 Layer

Cabinet Preparation

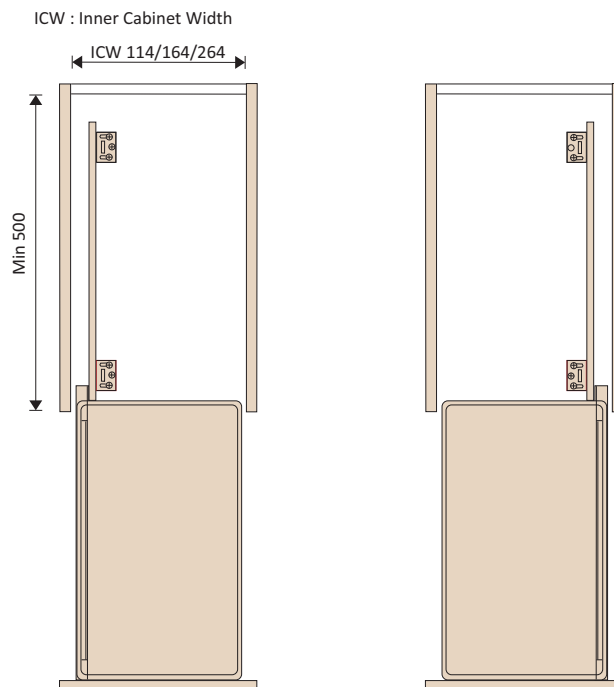

NKF941/942-Glass Larder Unit



Features

- 5 Layer glass larder unit for 500 and 600 mm cabinets
- Chrome finished with melamine base
- Anti skid mat included with the trays
- Tray height fully adjustable
- Integrated soft-closing damper
- Easy access to everything in the cabinet

Technical Specification

- Weight capacity for each tray 15Kg
- Cabinet height range 1720 to 2020mm
- Non-handed installation
- Order frame, tray and slider separately



Min. Inner Cabinet width	Cabinet Size	Inner Cabinet Height Range	Min.Inner Cabinet Depth	Basket Size W x D	Item Code
464	500	1684 - 1984	514	373 x 465	NKF-941
564	600	1684 - 1984	514	473 x 465	NKF-942

Technical Drawing

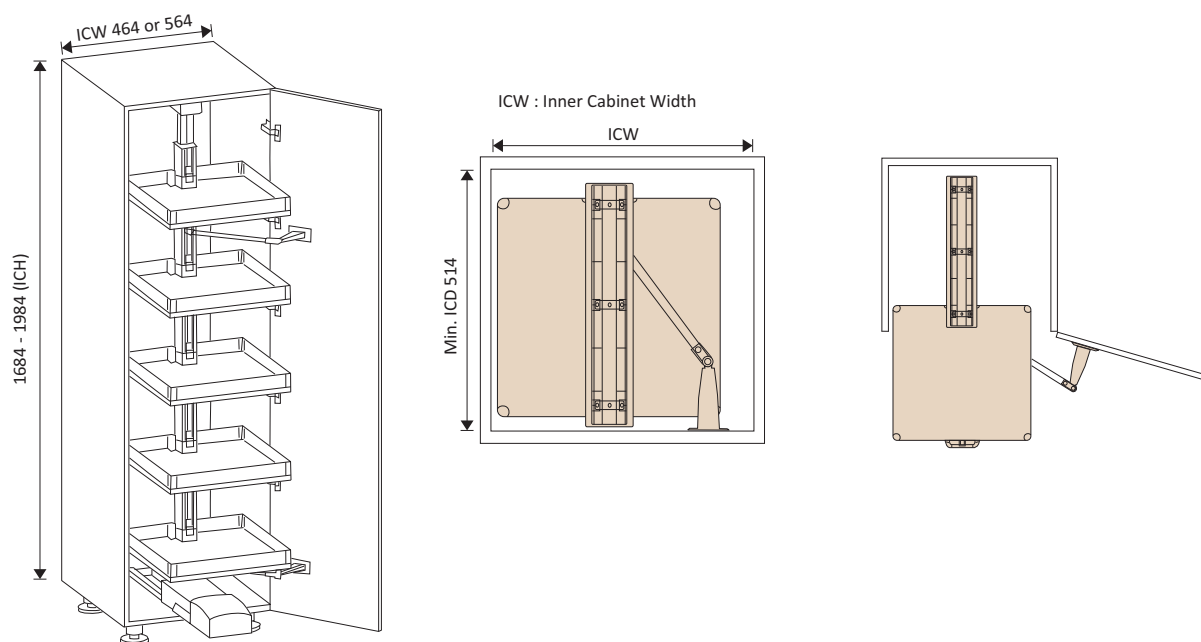

NKF953/954-Tandem Pantry with Glass Rail



Features

- 6-Layer tandem pantry with transparent sides
- Available for 450 & 600mm cabinet
- Product designed to ensure cabinet front is load free
- Easy access to everything in the cabinet

Technical Specification

- Weight capacity per inner basket 10Kg
- Weight capacity per outer basket 5Kg
- Non-handed installation
- Order frame and tray separately



Min. Inner Cabinet width	Cabinet Size	Min. Inner Cabinet Height	Min. Inner Cabinet Depth	Basket Size (W x D)		Item Code
				Outer Basket	Inner Basket	
414	450	1784 6-Layer	514	295 x 135	362 x 245	NKF 953
564	600	1784 6-Layer	514	450 x 140	520 x 250	NKF 954

Technical Drawing

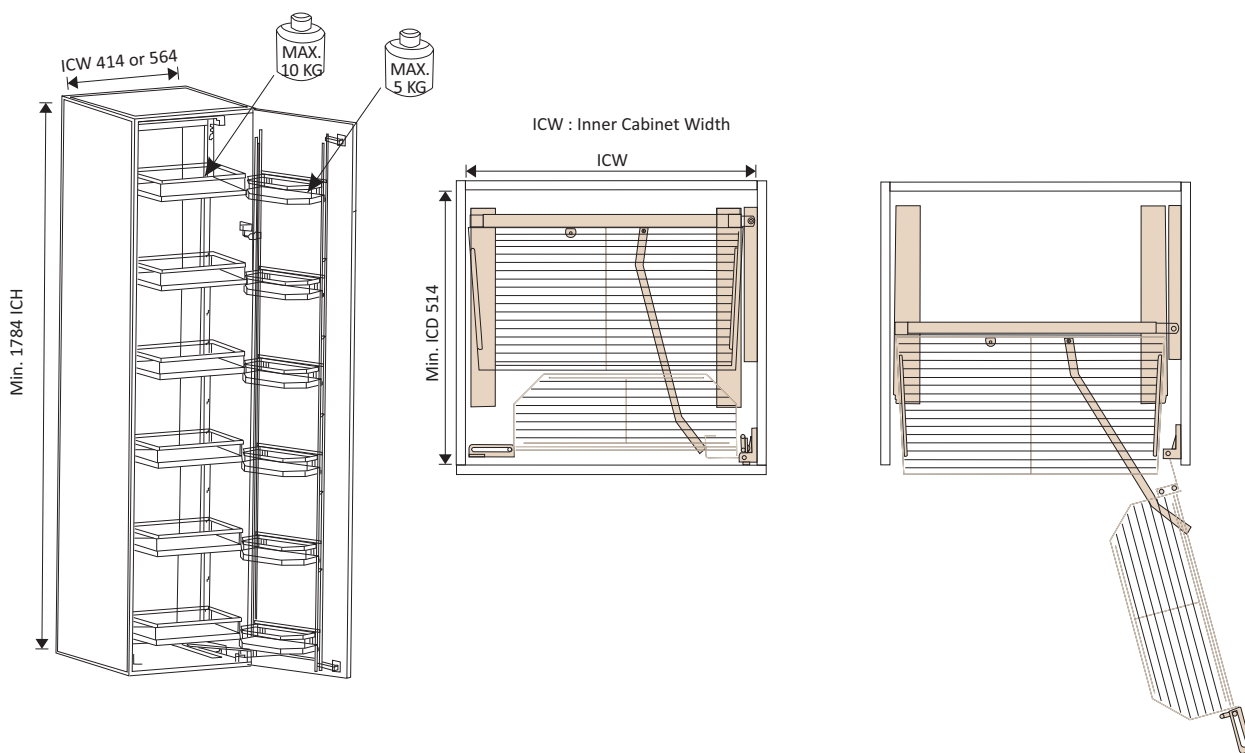

Features

- 6 Layer tandem pantry pullout for 450 and 600 mm cabinets
- Chrome finished with melamine base
- Product designed to ensure cabinet front is load-free
- Door and pullout shelf ensures full use of space
- Easy access to everything In the cabinet

Technical Specification

- Weight capacity per inner basket 10Kg
- Weight capacity per outer basket 5Kg
- Non-handed installation
- Order frame and tray separately



Min. Inner Cabinet width	Min. OW	Min. Inner Cabinet Height	Min. Inner Cabinet Depth	Basket Size (W x D)		Item Code	
				Outer Basket	Inner Basket		
414	450	1860	6-Layer	514	320 x 275	370 x 145	NKF955
564	600	1860	6-Layer	514	420 x 145	470 x 275	NKF956

Technical Drawing

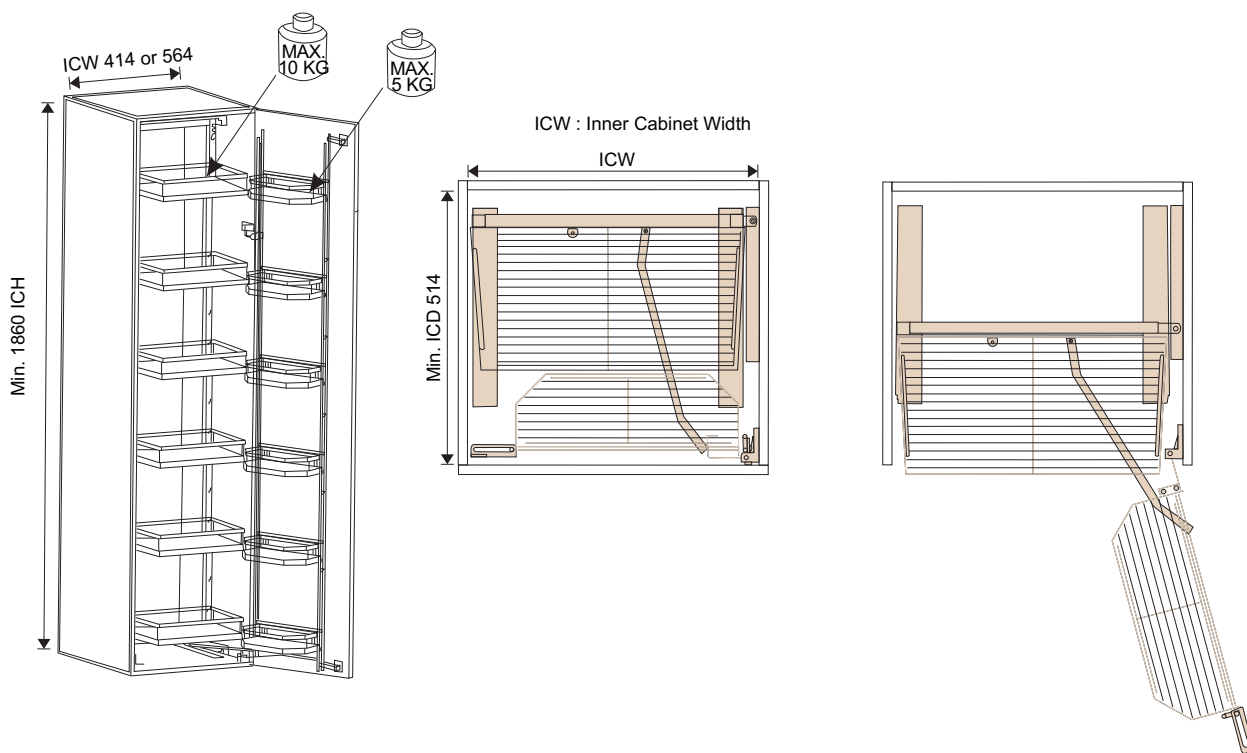

NKF961-Pull Down Storage System for Wall Cabinets



Features

- Pull down fitting with 2 trays with silent landing and re-positioning
- The 2 trays can be pulled down upto the eye level of the user to enable easy access
- Suitable for storing cutlery and less frequently used utensils
- Power can be adjusted by using knobs

Technical Specification

- Total weight capacity of 18kgs
- Suitable for 600mm cabinet with 300mm clear depth



Min. ICW	Finish	Item Code	Min. ICH	Min. ICD
564	SS	NKF 961	564	300

Technical Drawing

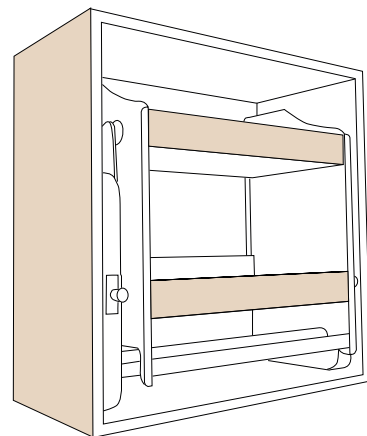
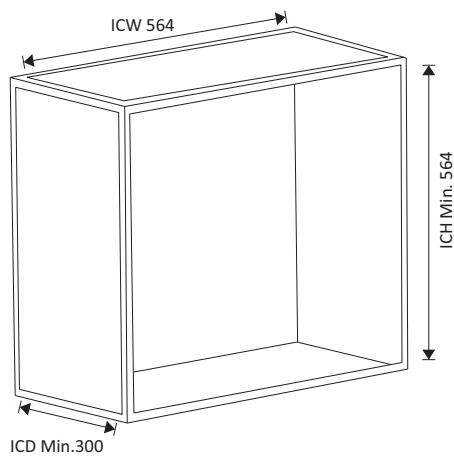

Features

- Transforms the aesthetics of the kitchen whilst adding the functionality to hide appliances or utensils
- Shelves can be made inside the cabinet
- Available for 450mm and 600mm cabinets
- Made from Aluminum material in SS and Silver Anodized finish



Technical Specification

- Maximum Inner Cabinet Height 1284mm
- Usable cabinet height: Cabinet Height-175mm
- Suitable for 18/19mm Panels
- Cover Strips can be cut and adjusted on site

Exact ICW	Finish	Item Code	Side Panel	Max. ICH	Min. ICD
414	Alu & SS	NKF 701	18/19	1284	300
564	Alu, SS, BK & WH	NKF 702	18/19	1284	300

Technical Drawing

Aluminium Rolling Shutter

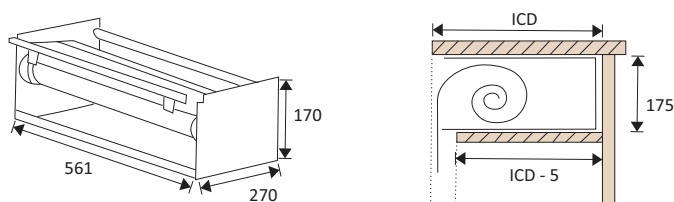

Glass Rolling Shutter

